

**48" MANHOLE - EXTENDED BASE
WITH REDUCING CONE**

**FLATTOP ILLUSTRATION
FOR SHALLOW MANHOLE**

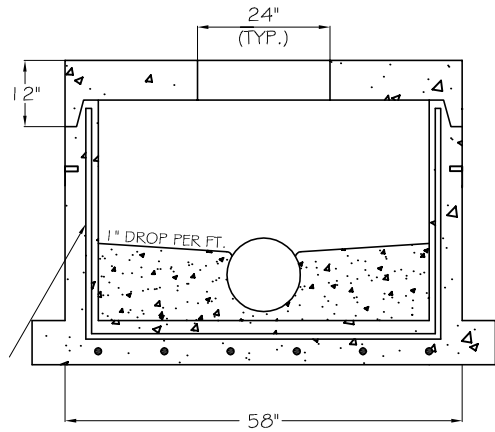

#3 BAR 12" O.C. WITH EACH WAY

3"X8"W3XW2.5 WELDED WIRE
IN ALL SURFACES & BOTTOM

GENERAL NOTES:

- WATER TIGHT GASKETS AT ALL PIPE CONNECTIONS
- HOLES AS SPECIFIED - MAX. DIA. = 28" DIA.
- AVG. WEIGHT OF 2' DEEP BASE W / 8" INVERT = 5000# - RISER WEIGHT = 800# / VT.F
- MANUFACTURED TO YOUR SPECIFICATIONS
- INVERT DEPTH SHALL BE EQUAL TO THE LARGEST PIPE DIAMETER
- MEETS OR EXCEEDS ASTM-C-478-95 REQUIREMENT
- CLASS I CONCRETE WITH DESIGN STRENGTH OF 5000 PSI AT 28 DAYS.

**The Turner
Co.**

DRAWN BY: DJH JOB NO: DATE: 3/22/2010

CUSTOMER & PRODUCT
**48" I.D. MANHOLE -
EXTENDED BASE**

JOB NAME